

Series '810' Peristaltic Pumps

The 810 series peristaltic pumps have a 12v DC motor with 6.4mm, 55 food grade santoprene tubing, delivering flow rates as high as 987 ml/min. They are self-priming up to 29 ft. (8.8m), can be run dry continuously, and are non-siphoning.

With peristaltic pumps the material to be pumped only comes in contact with the tubing. This is ideal for applications where the product to be moved or pumped should not touch any foreign materials e.g. when dispensing slurries, food products, chemicals, or other difficult to handle fluids.



The 810 peristaltic pumps can handle a wide variety of viscosities, from air and gases to heavy slurries, with a consistent positive displacement. It is available in 2 roller (powdered iron with nylon rollers and bronze bearings) or 3 roller (plastic with acetal rollers) assemblies. These attach directly to the motor output shaft, delivering a precise amount of the product with each revolution.

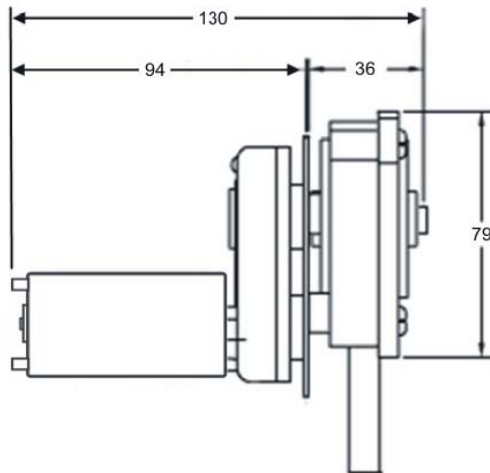

All Dimensions in mm

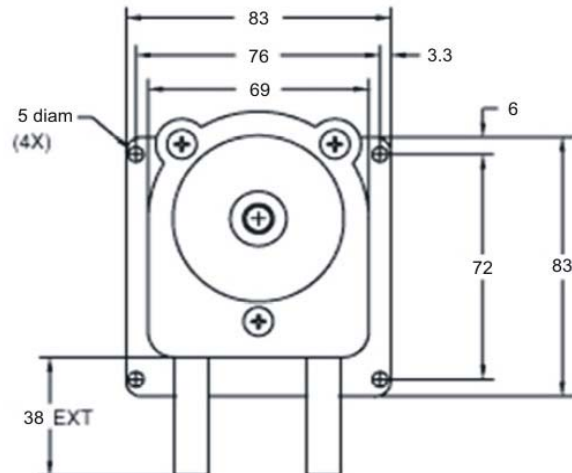

<u>Model No.</u>	<u>ml/min</u>	<u>Rollers</u>	<u>RPM</u>	<u>Voltage</u>	<u>Tube ID/Material</u>
810.040.012.250/2	140	2	40	12vDC	6.4mm, 55 food sant
810.040.012.250/3	120	3	40	12vDC	6.4mm, 55 food sant
810.090.012.250/2	315	2	90	12vDC	6.4mm, 55 food sant
810.090.012.250/3	270	3	90	12vDC	6.4mm, 55 food sant
810.143.012.250/2	501	2	143	12vDC	6.4mm, 55 food sant
810.143.012.250/3	429	3	143	12vDC	6.4mm, 55 food sant
810.282.012.250/2	987	2	282	12vDC	6.4mm, 55 food sant
810.282.012.250/3	846	3	282	12vDC	6.4mm, 55 food sant

liquid@liquidcontrols.com.au

www.liquidcontrols.com.au

Liquid Controls (Aust) Pty Ltd

3/1 Quist Crt.,
Dandenong Vic. 3175

P O Box 4174
Dandenong Sth. Vic 3175

Tele: 03 9794 7066
Fax: 03 9794 0641