

400 INDUCTION IP54 peristaltic pump

The 400 INDUCTION IP54 series of peristaltic pumps has been designed to offer the user a continuous duty, reliable and robust method of dosing a wide range of liquids at high volumes (700-5000ml min⁻¹). As with our standard AC and DC intermittent duty 400 series peristaltic pumps they have excellent suction performance, even priming from dry. Peristaltic pumps offer a good level of accuracy and repeatability and as only the tube contact the pumped media, they are corrosion resistant, easy to clean and inexpensive to maintain.

Normal displacement for the 400 series peristaltic pump is as follows:
 10mm ID = 18.75ml per revolution 13mm ID tube = 33.30ml per revolution

400 INDUCTION Series – Model Reference Numbers.

The 400 INDUCTION Series peristaltic pump is available in numerous configurations allowing you to specify tubing type, tubing bore ID, RPM, voltage, and fixed or variable speed control. All pumps can be ordered using a standard model reference number.

The first part relates to pump/motor & tubing The second part relates to RPM The third part relates to Voltage The fourth part relates to tubing ID	400: 400 series pump with Silicone , 401: 400-series pump with Santoprene® , 402: 400-series pump with Viton® . IND F: Fixed speed induction motor. IND V: Variable speed induction motor. 050, 060, 075, 100, or 150 RPM 230v (single phase), 400v (three phase) 100: 10mm bore diameter 130: 13mm bore diameter
--	--

For example: **401 IND F- 075 – 230 – 130 - XXX**

SERIES	FIXED/ VARIABLE	RPM	VOLTAGE	TUBE ID	SPECIAL
--------	--------------------	-----	---------	---------	---------

Is a 400 Induction series fixed speed pump fitted with 13mm ID Santoprene on a 75RPM 230v motor.

Occasionally a fifth digit will be present. However, this is for special order configurations only. Please contact us to discuss any requirements not listed here.



The **400 INDUCTION** series can be supplied in a number of fixed speed configurations from 50 to 150 RPM and additionally as a variable speed system fitted with a micro-inverter.

Due to the design of the induction motor and gearbox on the 400 INDUCTION series we can offer an IP54 rating to protect against dust and projections of water from all directions.

The standard induction motor supplied is normally rated at 25W High power 40W motors are available in certain configurations.

Certain variable speed models can be powered with a 100-120v AC supply

Contact us to discuss your particular application.

Summary of technical features:

- Self priming to 5 meters, even when dry.
- Stainless steel BB rotor assembly fitted as standard.
- Range of variable & fixed speed motors from 50-150RPM.
- IP54 motor/gearbox for operation in harsh environments.
- Available in Silicone, Viton and Santoprene tubing versions.
- Length of pump/motor assembly variable from 185-195mm.

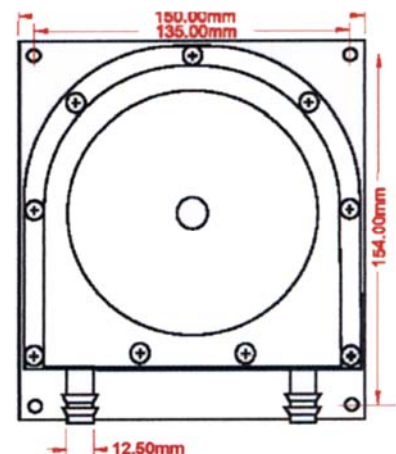

400 INDUCTION Series – further information

There is now has a new larger internal diameter smooth bore stainless steel spigot available for use with the 400 INDUCTION series pumps (13mm ID tubing only) to further enhance flow rates and offer an alternative spigot material where the existing material is unsuitable. The OD of the external spigot suits 16mm ID tube. To order pumps with smooth bore stainless spigot simply add 'SB' to the end of the pump model number, for example:



401-240-024-130-SB

denotes a 400 series pump with the smooth bore stainless spigots and a 240rpm 24vDC motor fitted with 13mm santoprene tube.

Use of the smooth bore spigots can give an increase in flow of as much as 40% in comparison to the flow rates provided for the standard spigots (see page 1 of this data sheet).

400 INDUCTION Series – Available voltages and motor speeds

Not all motors are available in every voltage. Due to fluctuation in demand for these pumps may not always be able to offer all listed motor speeds from stock – please contact our sales team to discuss your requirements

liquid@liquidcontrols.com.au

www.liquidcontrols.com.au

Liquid Controls (Aust) Pty Ltd

3/1 Quist Crt.,
Dandenong Vic. 3175

P O Box 4174
Dandenong Sth. Vic 3164

Tele: 03 9794 7066
Fax: 03 9794 0641