

DEPA® Air Operated Diaphragm Pumps

Series M High Pressure Type DB für Delivery Pressures up to 21 bar

Ideal for closed delivery (dead head) applications or where air pressure is abnormally low.

DEPA air driven diaphragm pumps provide a cost saving solution for dead head applications since they require no costly controls. Due to the pressure compensation between the air and product sides, the pump simply stops working in these conditions, without generating heat, wear or leakage.

Thanks to these features, DEPA air driven diaphragm pumps have been widely used for filter press feeding duties for many years. Standard Series M models already achieve 6.5 bar filter pressure with an applied air pressure of 7 bar. Many operators want still higher pressures for greater filter press efficiency and the DB High Pressure version of the DEPA Series M air operated diaphragm pumps has been developed to fulfil this requirement. These pumps can achieve a delivery pressure of 21 bar with a driving air pressure of 6 bar.

Standard Equipment

Maintenance free control system, stainless steel base frame with integral anti-vibration mounts, flanged construction, air inlet filter and a new design muffler. Drain and vent connections are also provided.

Further Accessories

Pulsation dampeners, monitoring and control systems, various transport devices, plus various couplings and adaptors for suction and discharge connections and for air connections.

- Exceptionally economical in operation against a closed discharge (i.e. filter press). No special control devices required.
- Diaphragm is pressure loaded giving equal pressure on both sides of the diaphragm.
- Good performance on low pressure pumping duties where air supply pressure is low.
- Ideal for abrasive, viscous, shear sensitive and solids bearing media.
- Tolerance of dry running and harsh usage.
- Minimal maintenance with no lubrication or oil required.
- Completely enclosed units with no bearings or rotary seals in contact with the product stream.
- Air operation means suitability for explosive and hazardous areas plus easy control by simply regulating the air supply.
- No need for electric motors, special drives or base plates.
- Easily portable and ready to use by simply connecting to air supply.
- Can be run against a closed discharge — a vital benefit for use on filling machines and filter presses.
- Self priming.
- Rugged construction in ductile iron or cast stainless steel.

- Three connection sizes: 1in., 1½in. and 2in.

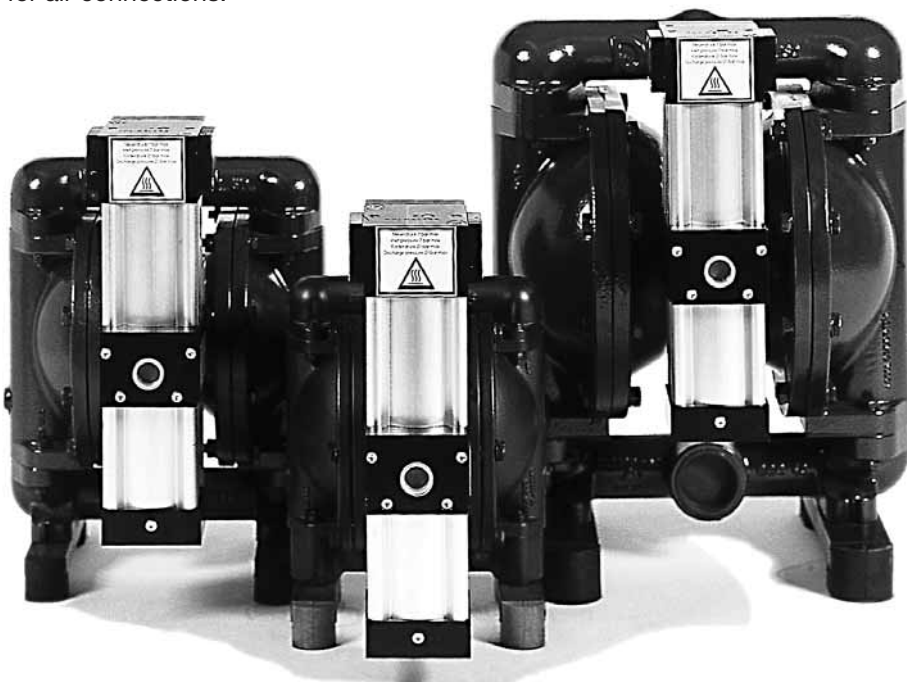

CRANE®

DEPA® Air Operated Diaphragm Pumps

Series M High Pressure Type DB

Operating Principle

DEPA Series M pumps deliver the pumped medium alternately via two pump chambers. In this case, driving air enters through the control valve at the rear of the corresponding diaphragm in operation, so displacing the medium from alternate pump chambers.

The pressure multiplier increases the pressure of the incoming air. With an air supply pressure of 6 bar, a maximum pumping pressure of 21 bar can be attained.

Under load or against a closed discharge, the pump will stop and hold the given pressure without stress on the pump components and without need of additional control devices.

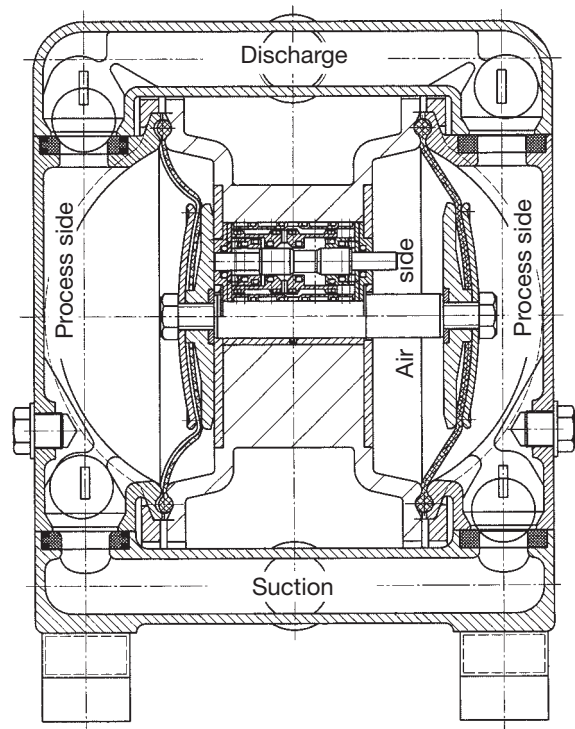

Materials of construction available as standard series:

DB 40

–

SA

–

D E E

Pump size		
Connections 1", DN 25	25	
Connections 1½", DN 40	40	
Connections 2", DN 50	50	

Major subassemblies			
Housing	Wetted piston	Centre block	
Cast stainless steel AISI 316 (1.4408)	Stainless steel AISI 321 (1.4541)	Cast aluminium	SA ¹⁾

Internals	Diaphragm	Seats	Balls
NRS	B	B	–
NBR (Buna N)	N	N	–
EPDM (Nordel)	E	E	–
EPDM (high press.)	D	–	–
EPDM (grey)	G	G	–
FKM (Viton)	F	F	–
PTFE (Teflon)	T	T	T
Stainless steel	–	–	R
NBR, steel core	–	–	Y
EPDM, steel core	–	–	W
EPDM, grey with steel core	–	–	X
PTFE, steel core	–	–	Z

¹⁾ Equipped with safety valve.

²⁾ Pumps equipped with PTFE diaphragms, valve balls and valve seats will have considerably reduced suction lift ability.

Particle size and suction lifts			
Pump size	25	40	50
Particle size mm	4	6	8
Suction lift in mWC dry ²⁾	5.5	5.8	5.8
Wetted ²⁾	8.7	9	9

Maximum operation temperature		°C
Metal pumps with internal	of NRS	70
	of NBR	90
	of FKM	120
	of PTFE	110
	of EPDM	90

DEPA® Air Operated Diaphragm Pumps

Series M High Pressure Type DB

Performance characteristics

DB25

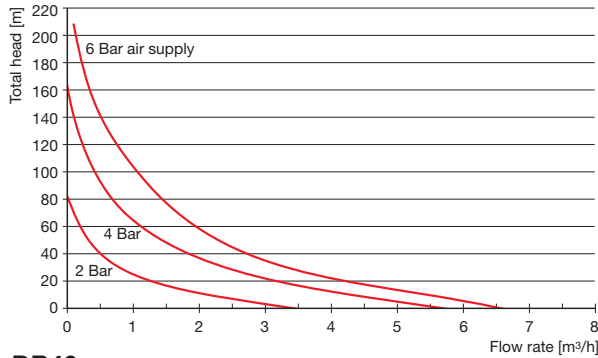

DB25

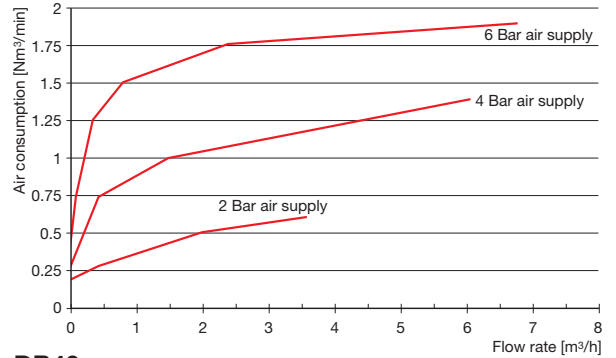

DB40

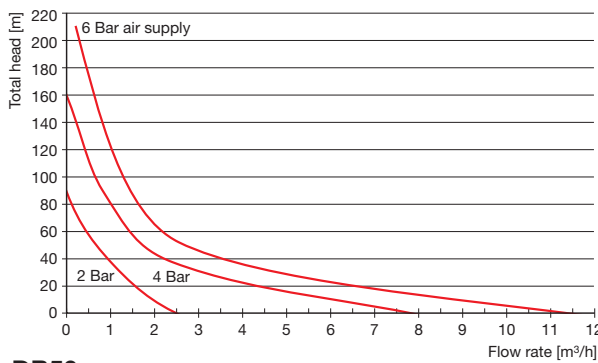

DB40

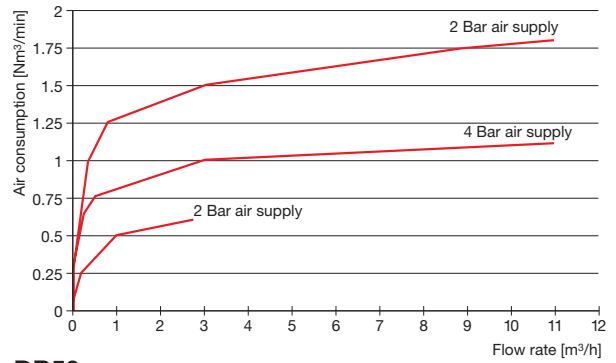

DB50

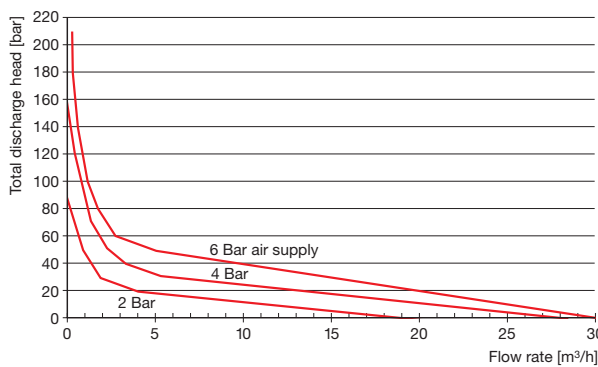

DB50

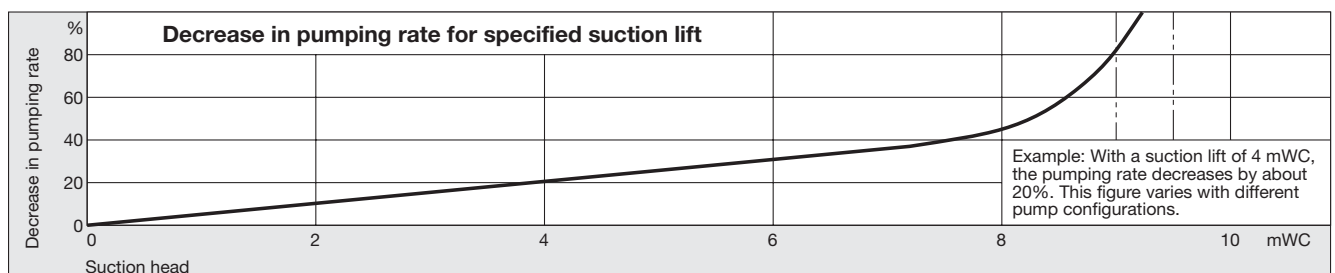
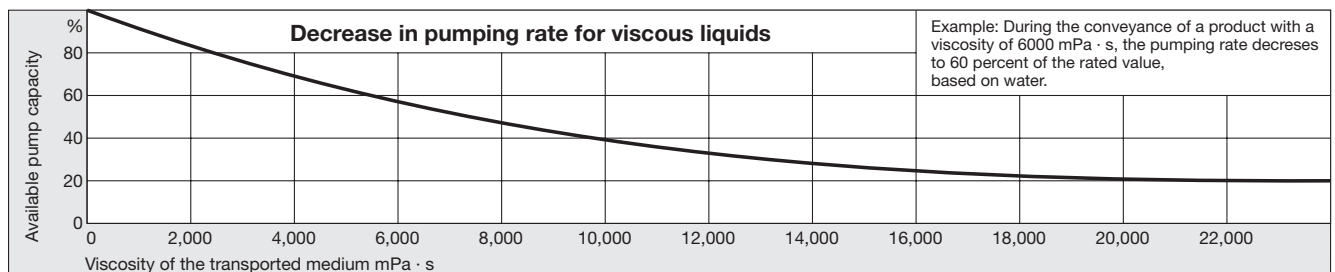
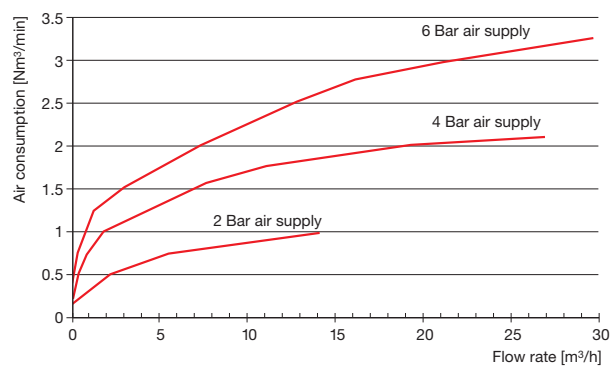

DEPA® Air Operated Diaphragm Pumps

Extremely rugged construction reduces downtime to a minimum.

DEPA air operated diaphragm pumps have been designed in such a way that all components in contact with the product can be disassembled and reassembled within a few minutes. This means that servicing work is reduced to the absolute minimum.

DEPA air operated diaphragm pumps have been developed as a modular system. Consequently, many components—some of which are common to all versions—are mutually compatible and interchangeable.

This flexible construction allows quick and simple changing of the internals for all Type DB models, to fulfil different applications.

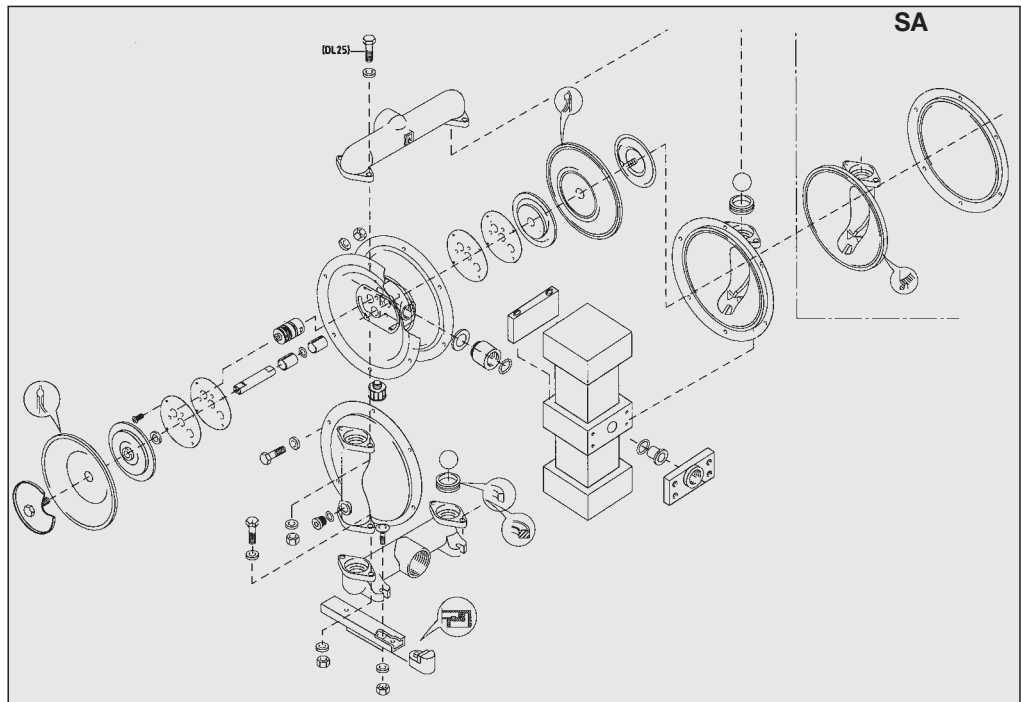

Pump weight in kg	Housing type SA
Pump size 25	30
41	41
50	72

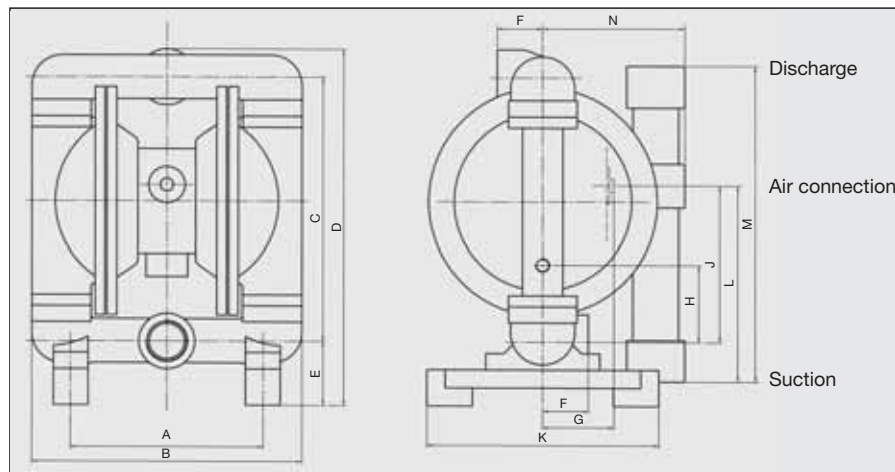

Dimensions for DB sizes

	Size		
	DB 25	DB 40	DB 50
A	190	220	280
B	236	310	412
C	241	305	414
D	322	406	540
E	61	72	88
F	35	50	65
G	84	84	105
H	71	93	125
J	141	179	245
K	200	255	340
L	165	165	165
M	380	380	380
N	269	269	320

Dimensions in mm

